



Features:

- RoHS Compliant
- Best Suited for ECL / PECL Logic Devices
- Very Low Phase Jitter, Excellent Noise Margin, No Internal PLL
- Leadless Chip Carrier (LCC) Ultra Small Package 7.0x5.0x2.0mm
- Complimentary Output, Tri-State Enable/Disable Standard or Option

ELECTRICAL SPECIFICATIONS	
Frequency Range (MHz)	10.0 to 320 MHz
Input Voltage (Vcc)	+3.3 VDC \pm 0.3 VDC
	+2.5 VDC \pm 5%
Overall Frequency Stability	\pm 100ppm; \pm 50 ppm; \pm 25ppm; \pm 20ppm
Temperature Range	0°C to +70°C; -40°C to +85°C
Standard Stability	\pm 50ppm / 0°C to 70°C
Symmetry	60/40%; 55/45%; 52.5/47.5%;
Output Load	50 Ohms to Vcc – 2V Thevenin Equivalent, Bias Required
Logic "1" / Logic "0" Level	(Vcc -1.02V) Min. / (Vcc -1.63) Max
Rise and Fall Time (Tr/Tf)	1 ns Max. Measured Between 20% to 80% Vp-p
Start Up Time	5 ms Max.
Phase Jitter (RMS, 1 Sigma)	1 ps Max. fj > 1 kHz; 0.3 ps fj = 12 kHz to 20 MHz
Tristate Function	Input (Pin 1) High (>0.7 Vcc) or Open: Output (Pin 4,5) Active
	Input (Pin 1) Low (<0.3 Vcc) or Open: Output Disabled in High Impedance
Enable / Disable Time	100 ns Maximum

Part Number Table					
Model	Input Voltage	Stability	Symmetry (Tristate)	Temp. Range (°C)	Frequency
BSM87P	3 = +3.3 VDC \pm 5%	B = \pm 100ppm	S = 55/45	Blank = 0° to 70°C	In MHz
	2 = +2.5 VDC \pm 5%	C = \pm 50ppm	Blank = 60/40	M = -40° to 85°C	
		E = \pm 25ppm	ST = 52.5 / 47.5		
		F = \pm 20ppm			

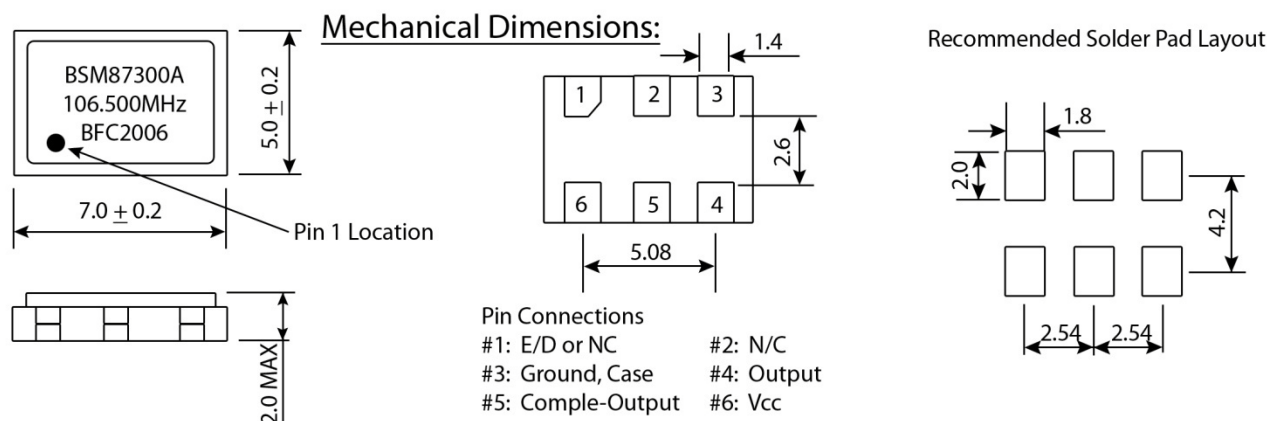

All dimensions are typical unless otherwise specified

Dimensions in Millimeters